



A small block making machine, simple to operate, basic and rugged, aimed for quality pavers and small kerbstones, S510 produces excellent wall blocks.

Ideal for small to medium community projects, it offers great versatility combined with remarkably good quality of output. Mechanical parts and hydraulic elements exceeding necessities guarantee long life and extreme reliability. Thanks to its compactness S510 is ideal to be transported to produce directly in the construction site.

## TECHNICAL FEATURES

Semiautomatic stationary block machine - Manual loading - Manual extraction

One-way vertical vibrator with adjustable speed

Adjustable vibration depending on production output

Mould size: cm 53 x 50 height min. cm 5 max. cm 25

Machine size: cm 160 x 115 x h160 - weight kg 1.000

Motors and power: 2 motors tot. 6 Hp (4,5 kW)

Pallets size: cm 60 x 51 x 4

Pallets per shift (8 hours): 550 pcs

Ancillary equipment needed: planetary mixer 300 lt + wheelbarrow & shovel + pallets



130

Blocks 20x40x20 per hour



12

Sq/mt. pavers per hour



130

Kerbs 50cm. per hour



Blocks per mould  
20x40x20: 2 pcs  
15x40x20: 3 pcs  
10x40x20: 4 pcs



Pavers per mould  
20x10: 10 pcs

Cycles per hour :

## 65

The production output for manual loading machines depends also on overall plant speed.

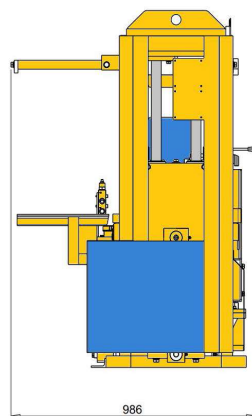
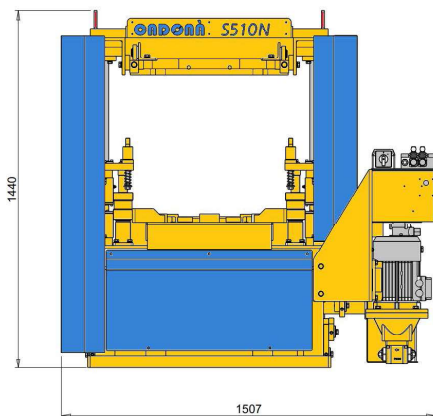

Dimensions of machine ready to work: cm 160 x 115 x 160 - weight kg 1.000

Example of packaging:  
S510 + 3 moulds- size 165x145x165



To complete the plant you will need: planetary mixer 300 lt + wheelbarrow & shovel + pallets

